

CAPITOLO 3

MÜLLER Fissaggio



Reggipiani



Reggipiano schiacciato

Acciaio

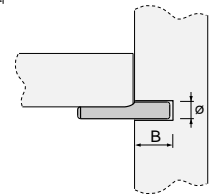
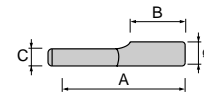

ø	A	B	C	Codice	
				Ottonato	Nichelato
4	19,5	8	2,3	2702 001 010	2737 000 010
5	23,7	10,5	3	2737 000 011	2730 008 001
6	23	11	3,4	2737 000 019	2737 000 020



Reggipiano con fermo

Acciaio

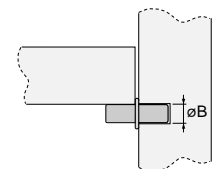
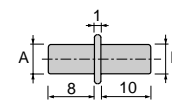

A	B	Codice	
		Zincato	Ottonato
4	4	2730 007 033	2730 007 034
4	5	2730 007 023	2730 007 024
5	5	2730 007 013	2730 007 014



Reggipiano doppio

Nylon

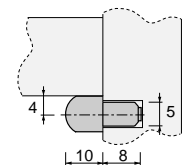
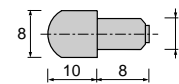

Finitura	Codice
Bianca	2731 003 206
Nera	2731 003 208
Noce	2731 003 207



Reggipiano con fermo

Nylon

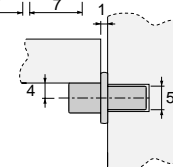
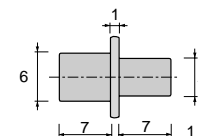

Codice		
Bianco	Marrone	Nero
2701 002 001	2701 002 003	2701 002 002



Reggipiano

Acciaio - Nylon

Finitura	Codice	
	ø3	ø5
Bianca		2737 000 016
Nero		2737 000 018
Neutro	2737 000 015	2737 000 021

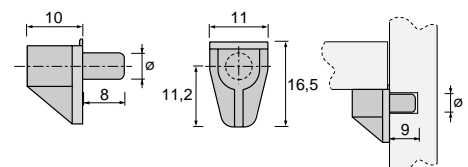

Reggipiani



Reggipiano

Nylon

Finitura	Codice	
	ø5	ø6
Bianca	2701 003 001	2701 003 021
Marrone	2701 003 003	2701 003 023
Nera	2701 003 002	2701 003 022

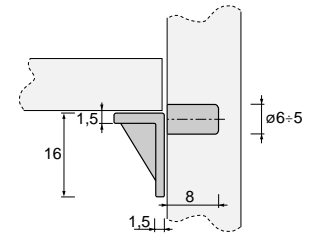

Reggipiano

Nylon

Finitura	Codice	
	Tipo A	Tipo B
Bianca	2701 006 003	2701 006 001
Marrone	2701 006 004	2701 006 002

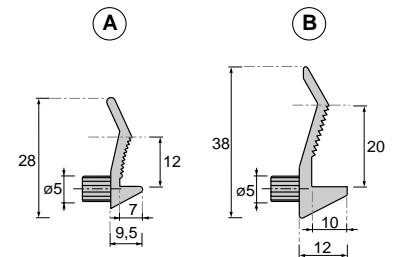

Reggipiano

Nylon

Finitura	Codice
Bianca	2702 001 001
Marrone	2702 001 003
Nera	2702 001 004

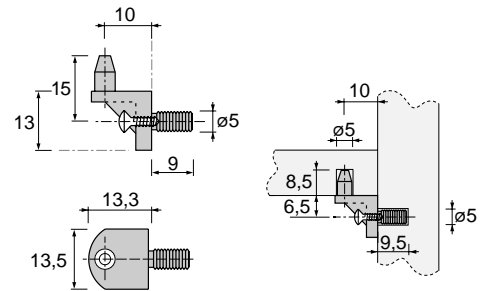

Reggipiano

Zama

Finitura	Codice
Nichelata	2736 001 015
Ottonata	2736 001 017

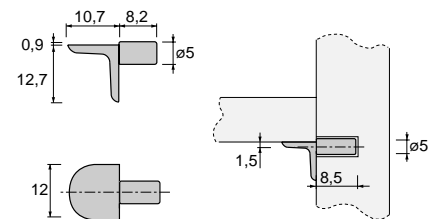

Reggipiano

Zama

Finitura	Codice
Nichelata	2736 001 016

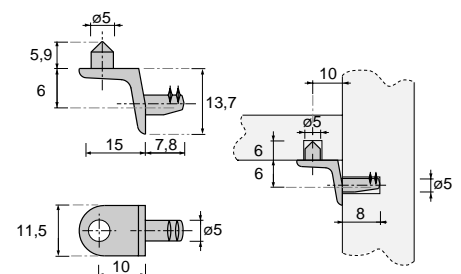

Reggipiano

Zama

Finitura	Codice
Nichelata	2702 001 020

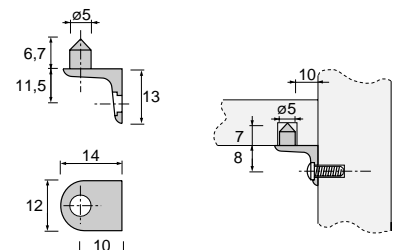

Reggipiani



Reggipiano con chiodo
Nylon

Finitura	Codice	
	Chiodo Fisso	
Bianca	2700 004 001	
Marrone	2700 004 003	

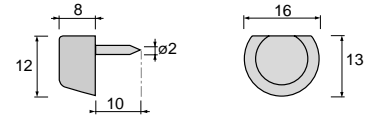

Reggipiano con chiodo

Finitura	Codice	
	Chiodo Fisso	Chiodo Mobile
Bianca	2701 004 001	2701 004 021
Marrone	2701 004 003	2701 004 023

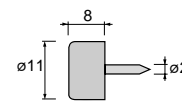

3



Reggipiano da avvitare
Ottone Gomma

Finitura	Codice
Bianca	2700 010 021
Marrone	2700 010 022
Nera	2700 010 023

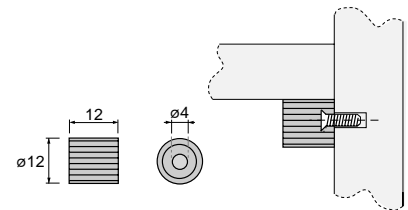

Reggipiano con bussola liscia
Ottone

Finitura	Codice	
	Bussola	Reggipiano
Lucida	2751 001 012	2730 001 012
Nichelata	2751 001 013	2730 001 013
Bronzato	2751 001 014	2730 001 014

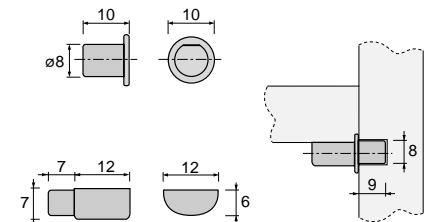

Reggipiano con bussola filettata
Ottone

Finitura	Codice	
	Bussola	Reggipiano
Lucida	2751 003 012	2730 006 012
Nichelata	2751 003 013	2730 006 013
Bronzata	2751 003 014	2730 006 014

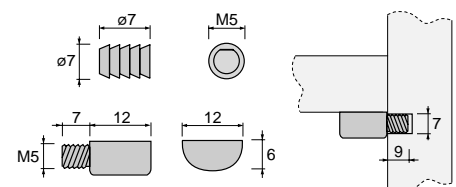

Reggipiano con bussola filettata
Ottone

A	B	Finitura	Codice	
			Bussola	Reggipiano
7	9	Lucida	2751 003 012	2730 004 012
7	9	Nichelata	2751 003 013	2730 004 013
7	9	Bronzata	2751 003 014	2730 004 014
8	10	Lucida	2751 004 012	2730 002 012
8	10	Nichelata	2751 004 013	2730 002 013
8	10	Bronzata	2751 004 014	2730 002 014

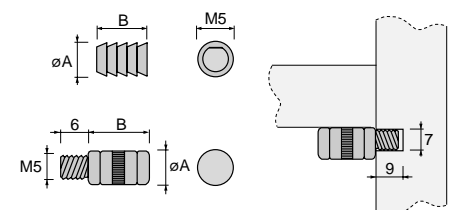

Reggipiani



Reggipiano per vetro

Acciaio-Nylon

Ø	Codice		
	Ottonato	Nichelato	Zn Nero
5	2736 001 001	2736 001 002	2736 001 003

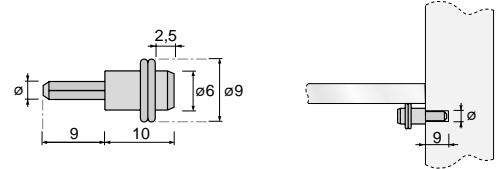

Reggipiano per vetro

Zama-Nylon

Finitura	Codice
Nichelata	2731 001 013
Ottonata	

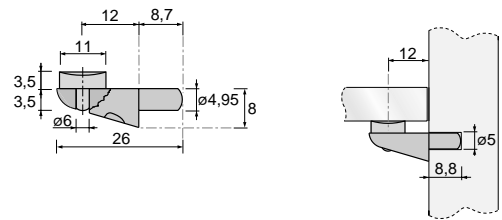

Reggipiano per vetro

Zama-Nylon

Finitura	Codice
Nichelata	2731 001 011
Ottonata	

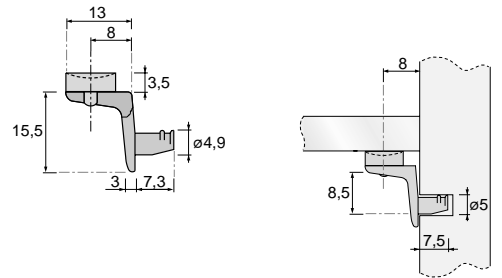

Reggipiano per vetro

Zama-Nylon

Finitura	Codice
Nichelata	2761 001 450

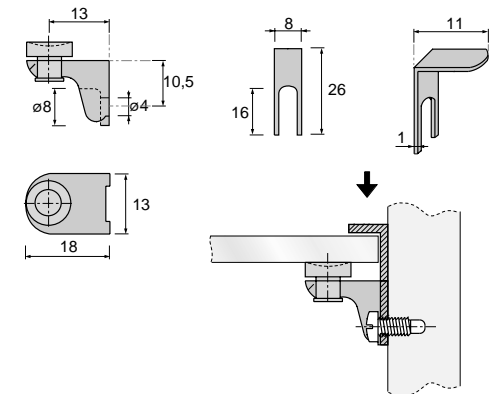

Reggipiano per vetro

Acciaio-Nylon

Tipo	Ø	Finitura	Codice
A	3	Nichelata	2737 000 001
A	5	Nichelata	2737 000 004
B	4,2	Nichelata	2737 000 007

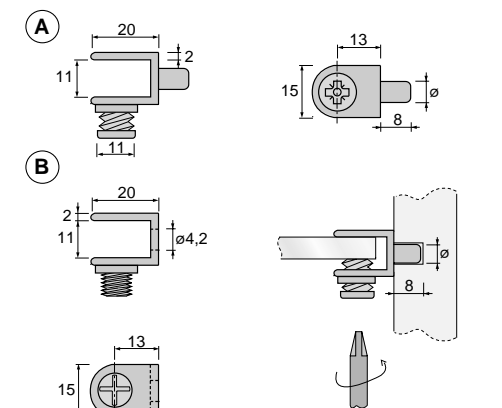

Reggipiani



Reggipiano ad incastro

Zama-Nichelato-Nylon

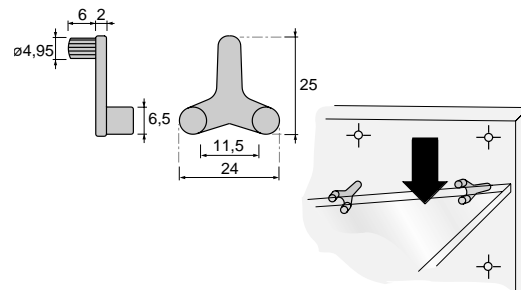

Finitura	Codice
Nichelata	2762 001 010



Ventosa per vetri

PVC

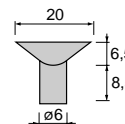

Finitura	Codice
Trasparente	2761 001 001



Reggipiano per vetro

zama
spessore vetro da 4 a 8 mm

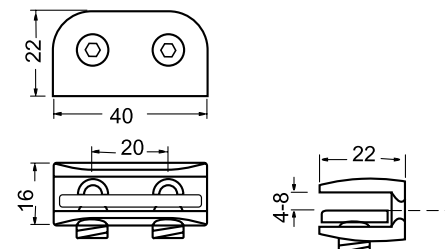

Finitura	Codice
Nichel satinato	2517 005 640



Reggipiano per vetro

zama
spessore vetro da 5 a 8 mm

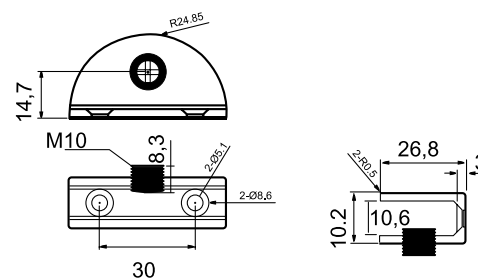

Finitura	Codice
Nichel satinato	2517 005 641



Supporto autobloccante

zama
per piani di cristallo da 3 mm a 7 mm
con perno da 5 mm

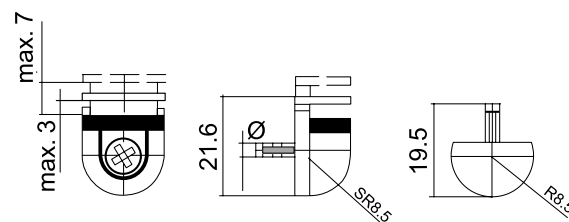

Finitura	Codice
Nichelata	2617 005 642

Reggipiani



Supporto autobloccante di metallo per piani di cristallo da 8-10-12 mm

Nichelato
Montaggio con perno

Finitura	Codice
Nichelata	4021 000 052

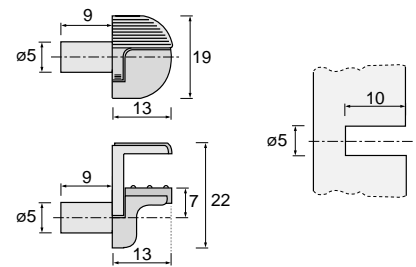

Supporto autobloccante di metallo per piani di cristallo da 6-8-10 mm

Nichelato
Montaggio con perno

Finitura	Codice
Nichelata	4021 000 053

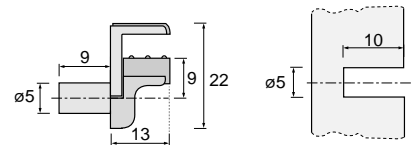

Supporto di metallo per piani di cristallo da 8-10-12 mm

Nichelato
Montaggio con vite

Finitura	Codice
Nichelata	4021 000 025

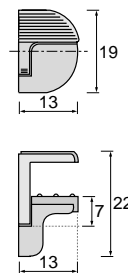

Supporto di metallo per piani di cristallo da 6-8-10 mm

Nichelato
Montaggio con vite

Finitura	Codice
Nichelata	4021 000 026

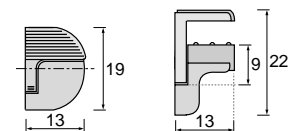

Perno filetto M4

da abbinarsi con Bussole ottone

Finitura	Codice
Nichelata	4021 000 027

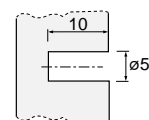

Vite di montaggio

Finitura	Codice	X
Nichelata	4021 000 028	9
Nichelata	4021 000 029	12

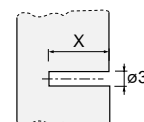

Reggipiani

Ventosa per cristallo



Finitura	Codice
Bianca	4021 000 031
Nera	4021 000 032
Trasparente	4021 000 030

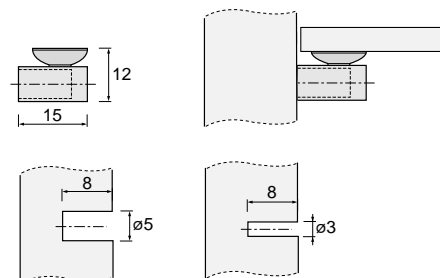

Perno filetto M4 per bussola estraibile



Finitura	Codice
Zincata	4021 000 037

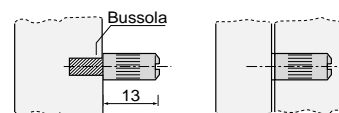

Perno senza filetto



∅	Finitura	Codice
3	Zincata	4021 000 033
5	Zincata	4021 000 034

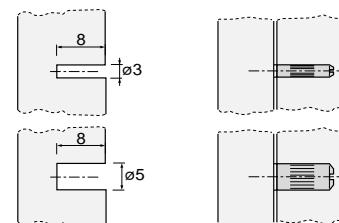

Perno filetto mordente



∅	Finitura	Codice
3	Zincata	4021 000 035
5	Zincata	4021 000 036

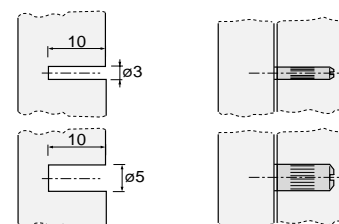

Reggipiani



Reggipiano angolo per vetro gomma

Metallo

Finitura	∅	Codice
Ottonato	5	2810 000 080
Nichelato	5	2810 000 070

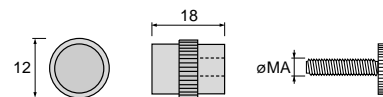

Reggipiano doppio per vetro gomma

Metallo

Finitura	∅	Codice
Ottonato	5	2810 000 060
Nichelato	5	2810 000 050

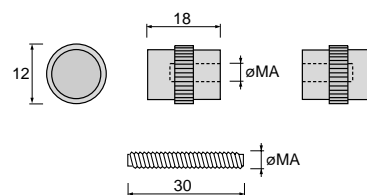

Reggipiano con filetto per gomma

Metallo

Finitura	∅	Codice
Ottonato	5	2811 100 012
Nichelato	5	2811 100 013

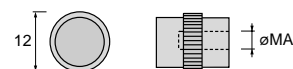

Barretta filettata

Acciaio nichelato

∅	Codice	L
5	2811 008 626	30
5	2811 008 628	25

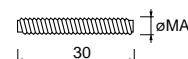

Reggipiano con foro passante

Metallo

Finitura	Codice
Ottonato	2811 008 623
Nichelato	2811 008 624



Reggipiani



Mensolina cilindrica per vetri

Ottone

Tipo	Codice	
	Dorato	Cromato
1	2518 000 011	2518 000 019
2	2518 000 012	2518 000 020
3	2518 000 013	2518 000 021
4	2518 000 014	2518 000 022
5	2518 000 015	2518 000 023
6	2518 000 016	2518 000 024
7	2518 000 017	2518 000 025
8	2518 000 018	2518 000 026

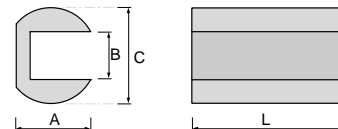

A	1	2	3	4	5	6	7	8
A	22	22	22	30	31	22	33	38
B	10	10	10	12	14	10	16	21
C	30	30	30	38	40	30	42	47
L	20	30	45	45	45	70	70	70

3

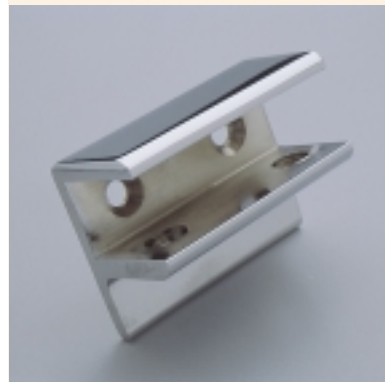

Mensolina con battuta per vetri

Ottone

Tipo	Codice	
	Dorato	Cromato
1	2518 000 039	2518 000 048
2	2518 000 040	2518 000 049
3	2518 000 041	2518 000 050
4	2518 000 042	2518 000 051
5	2518 000 043	2518 000 052
6	2518 000 044	2518 000 053
7	2518 000 045	2518 000 054
8	2518 000 046	2518 000 055
9	2518 000 047	2518 000 056

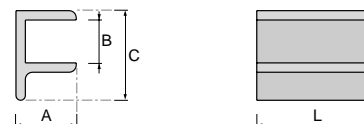

	1	2	3	4	5	6	7	8	9
A	21	21	21	21	21	21	21	21	21
B	10	12	14	10	12	14	10	12	14
C	29	32	34	29	32	34	29	32	34
L	30	30	30	45	45	45	70	70	70



Reggimensola a scomparsa

Acciaio-Nylon

Misura	Ø Tass.	L Tass.	Ø Piano	L Mensola	Codice
9 x 90	12	45	9	90	2518 700 010
9 x 140	12	45	9	140	2518 700 011
10 x 100	12	70	9	100	2518 700 013
10 x 145	12	70	9	145	2518 700 015
12 x 70	12	45	12	70	2518 700 016
12 x 120	12	70	12	120	2518 700 018
14 x 120	14	70	14	120	2518 700 020
14 x 140	14	70	14	140	2518 700 021
14 x 165	14	70	14	165	2518 700 022
14 x 200	14	70	14	200	2518 700 023

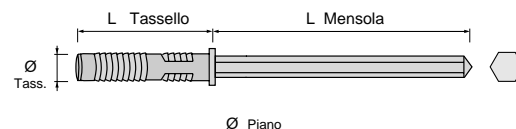

Reggimensola regolabile a scomparsa

Metallo

Spessore minimo pannello 24 mm
Esagono 10 x 114 mm

Finitura	Codice
Zincata	2617 505 322

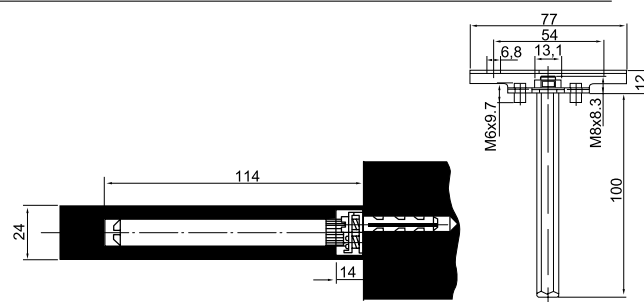

Reggimensole



Reggimensole AS

Acciaio-ABS

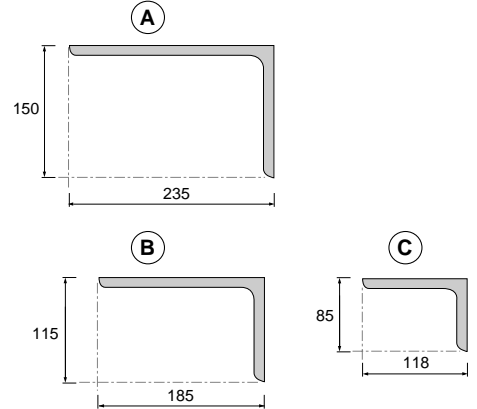
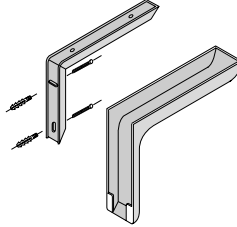

Finitura	Codice		
	A	B	C
Bianca	2517 009 200	2517 009 211	2517 009 213
Nera	2517 009 201	2517 009 210	2517 009 214
Marrone	2517 009 203	2517 009 206	2517 009 215
Beige		2517 009 208	
Frassino		2517 009 209	



Reggimensole ripiegabile

Metallo
Lunghezza 180 mm

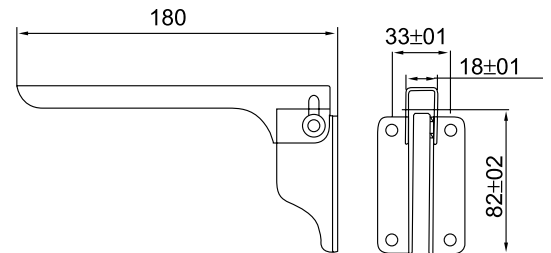

Finitura	Codice
Cromata	2617 760 900



Reggipiano per vetro

Ottone

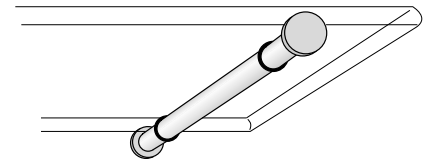

L	Codice	
	Dorato	Cromato
20	2517 001 001	2517 001 010
25	2517 001 002	2517 001 011

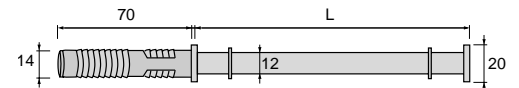

Reggimensole

Realizzata in pressofusione di alluminio

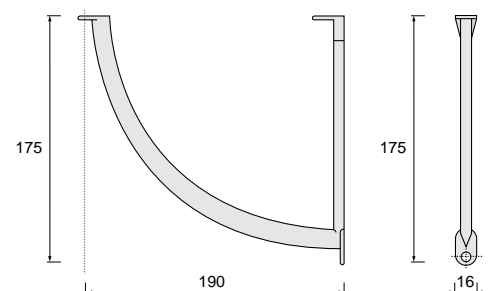

Finitura	Codice
Cromata	2517 009 308
Oro	2517 009 309

Reggimensole e fermaspecchi



Reggimensole regolabile Tucano

Nylon, metallo e guarnizioni in PVC
per spessori da 5 a 25 mm

Finitura	Codice
Bianco	2128 014 301
Nero	2128 014 302
Argento	2128 014 303

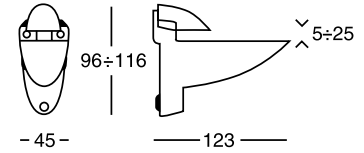

Reggimensole regolabile Eco

Nylon, metallo e guarnizioni in PVC
per spessori da 5 a 25 mm

Finitura	Codice
Cromato	2128 056 020

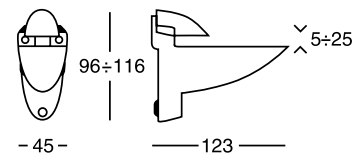

3



Fermaspecchio in metallo cromato

Metallo
Spessore specchio 6 mm

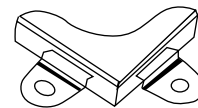

Tipologia	Codice
ad angolo	2617 553 04B
in linea	2617 553 04A

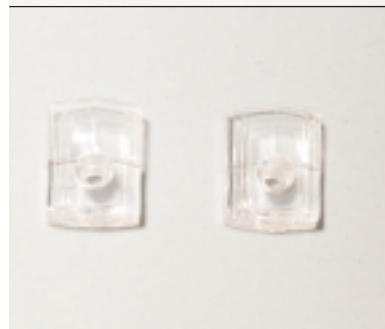

Fermaspecchio in nylon

Nylon
Spessore specchio 3-4 mm

Finitura	Codice
trasparente	2617 505 306

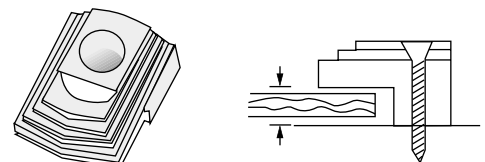

Fermaspecchio a molla

Metallo
Guarnitura composta da due pezzi superiori fissi e due pezzi inferiori a molla

Finitura	Codice
Cromata	2617 505 627

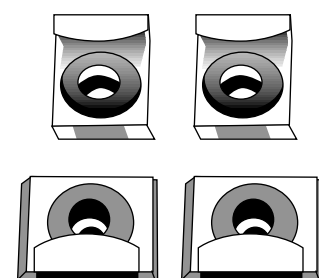

Reggipensili

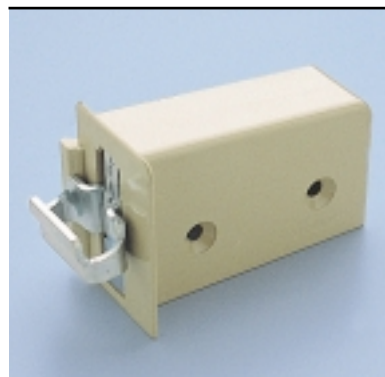

Reggipensile regolabile

Acciaio-Nylon

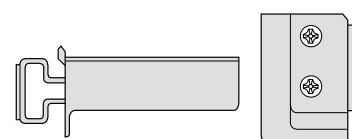
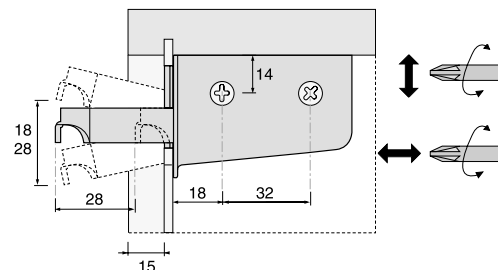

3

Finitura	Codice	
	DX	SX
Bianca	2517 463 011	2517 463 012
Marrone	2517 463 013	2517 463 014
Beige	2517 463 015	2517 463 016
Nichelata	2517 463 017	2517 463 018

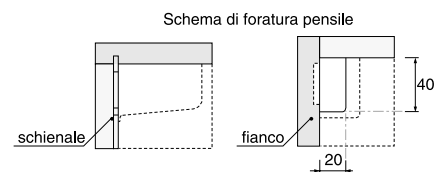

A

Barra reggipensile

Acciaio o alluminio



B



C

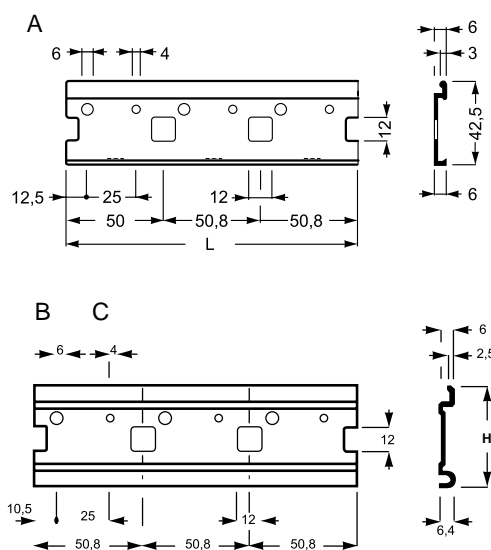

barre da ml. 2

	H	Materiale	Codice
A	42,5	Alluminio	2517 463 201
B	50	Acciaio	2517 105 150
C	37	Acciaio	2517 105 137

Sistema modulare

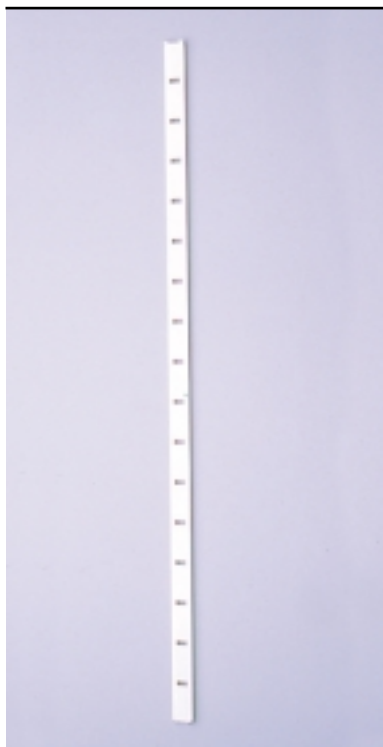

Sistema cremagliere

profilo verticale
alluminio anodizzato
mensolina alluminio anodizzato

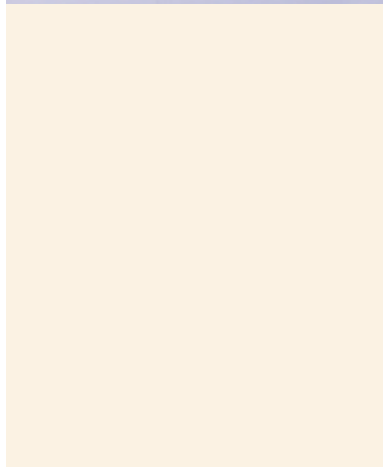
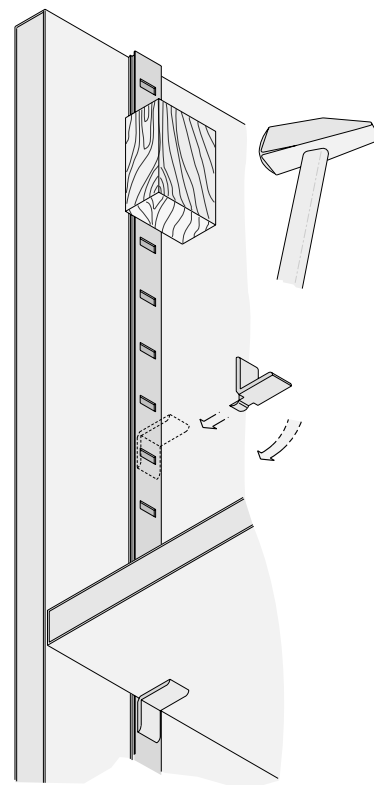

Profilo verticale ml. 3.50

Finitura	Codice
oro	2705 003 002
argento	2705 003 001

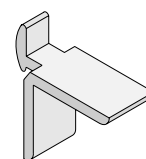
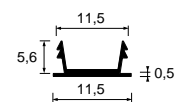
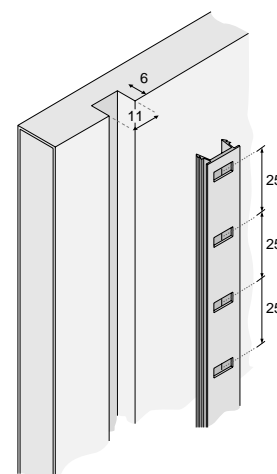

Mensolina reggipiano

Finitura	Codice
oro	2732 002 011
argento	2732 002 010

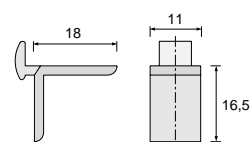

Sistema modulare

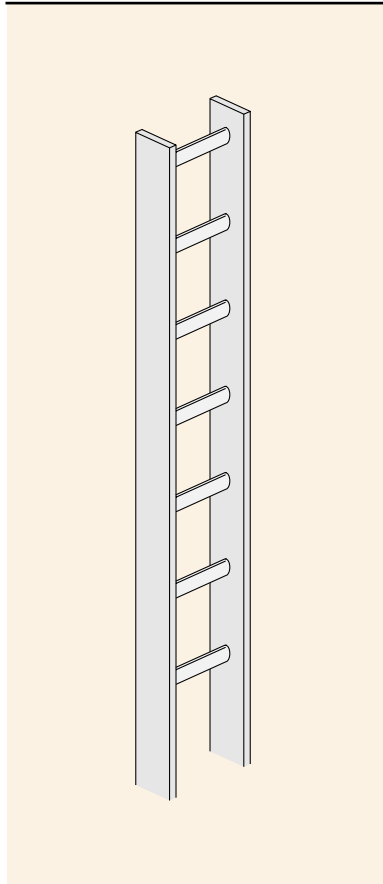

Sistema cremagliera

Finitura oro zecchino, bianca, nera

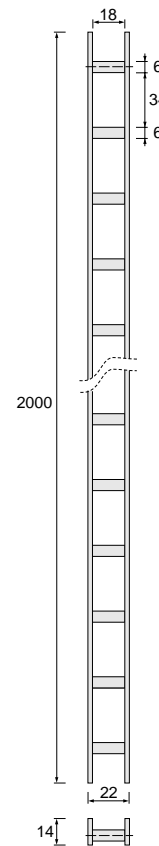

Finitura	Codice
oro zecchino	2813 001 022
bianca verniciata	2813 001 020
nera verniciata	2813 001 021

3



Mensola per cremagliera

Finitura bianca, nera, oro zecchino

A	B	Finitura	Codice
15	56	bianca	2813 001 027
15	56	nera	2813 001 032
15	56	oro zecchino	2813 001 036
22	57	bianca	2813 001 028
22	57	nera	2813 001 033
22	57	oro zecchino	2813 001 037
30	62	bianca	2813 001 030
30	62	nera	2813 001 034
30	62	oro zecchino	2813 001 038
40	98	bianca	2813 001 031
40	98	nera	2813 001 035
40	98	oro zecchino	2813 001 039

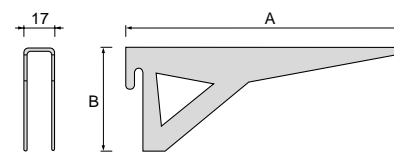

Cavallotto per fissaggio cremagliera

Finitura bianca, nera, oro zecchino



Finitura	Codice
oro	2813 001 040
bianca	2813 001 026
nera	2813 001 041

Sistema modulare



Sistema cremagliera

Metallo

Finitura epossidica bianca e nera e finitura cromata

Feritoia singola

L	Codice
	Bianca
600	2617 601 060
900	2617 601 090
1200	2617 601 120
1500	2617 601 150
1800	2617 601 180
2100	2617 601 210
2400	2617 601 240

Feritoia doppia

L	Codice
	Bianca
1800	2617 602 180
2100	2617 602 210
2400	2617 602 240

A richiesta nera e cromata

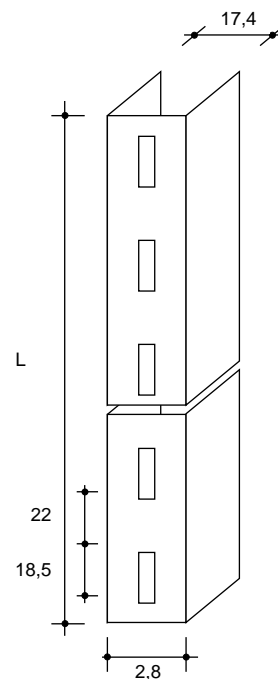

Mensole per cremagliera

Finitura epossidica bianca e nera e finitura cromata

L	Codice
	Bianca
150	2617 607 150
200	2617 607 200
250	2617 607 250
300	2617 607 300
350	2617 607 350
400	2617 607 400
450	2617 607 450
500	2617 607 500

A richiesta nera e cromata

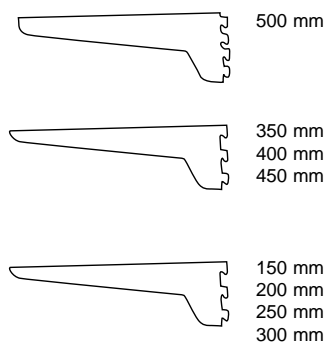

Cavalieri per reggimensola

Acrilico

Finitura trasparente

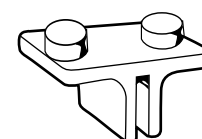

Tipologia	Codice
Centrale	2617 676 010
Laterale	2617 676 010

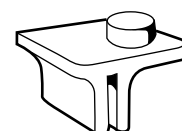

Congiunzioni per vetri



Congiunzione per vetri

Materiale: acciaio inox
Spessore vetro: 10-12 mm

Congiunzione: vetro - vetro a 3 pezzi

Finitura	L	Codice
Inox satinato	60	1100 160 160
Inox satinato	82	1100 160 182

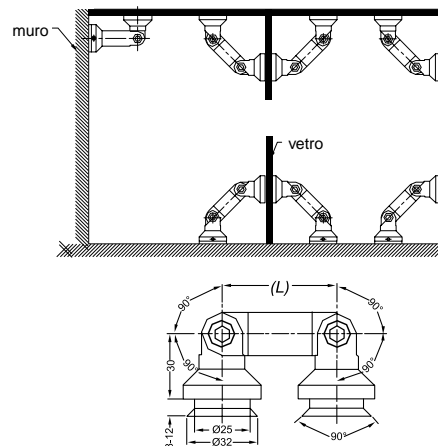

Congiunzione per vetri

Materiale: acciaio inox
Spessore vetro: 10-12 mm

Congiunzione: vetro - muro a 3 pezzi

Finitura	L	Codice
Inox satinato	60	1100 160 260
Inox satinato	82	1100 160 282

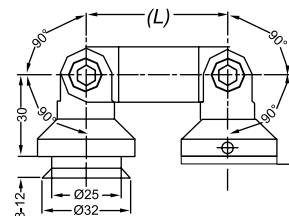

Congiunzione per vetri

Materiale: acciaio inox
Spessore vetro: 10-12 mm

Congiunzione: vetro - vetro a 5 pezzi

Finitura	L	Codice
Inox satinato	60	1100 160 360
Inox satinato	82	1100 160 382

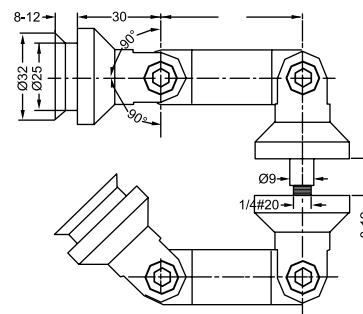

Congiunzione per vetri

Materiale: acciaio inox
Spessore vetro: 10-12 mm

Congiunzione: vetro - muro a 2 pezzi

Finitura	L	Codice
Inox satinato	75	1100 160 400

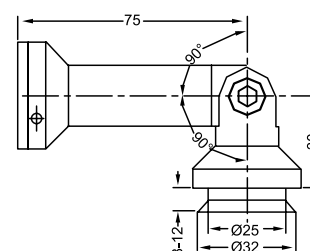

Congiunzioni per vetrate



Congiunzioni per vetrate

Materiale: acciaio inox

Congiunzione ad 1 braccio

Finitura	Codice
Inox satinato	1100 SS2 001

N.B.: a richiesta si può avere anche Inox lucido

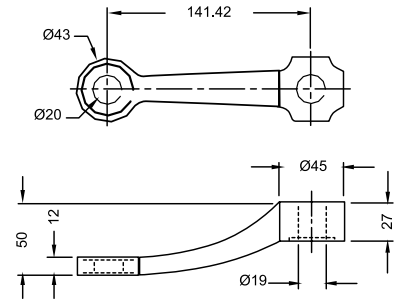

Congiunzione a 2 bracci

Finitura	Codice
Inox satinato	1100 SS2 002

N.B.: a richiesta si può avere anche Inox lucido

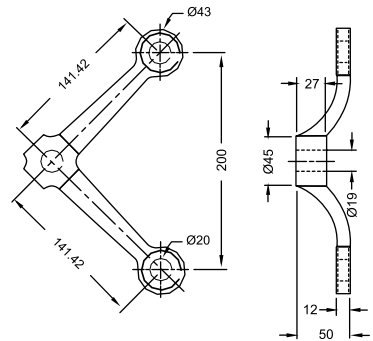

Congiunzione a 3 bracci

Finitura	Codice
Inox satinato	1100 SS2 003

N.B.: a richiesta si può avere anche Inox lucido

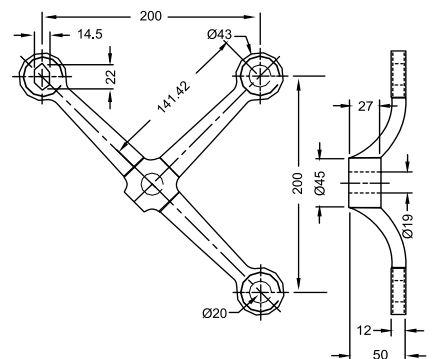

Congiunzione a 4 bracci

Finitura	Codice
Inox satinato	1100 SS2 004

N.B.: a richiesta si può avere anche Inox lucido

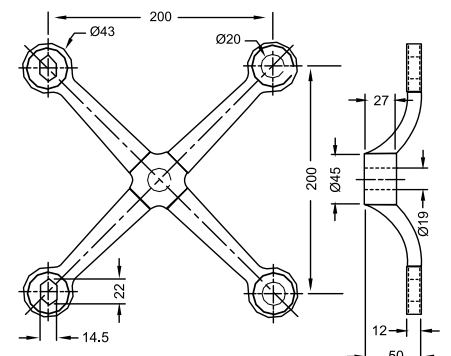

Congiunzioni per vetrate



Congiunzioni per vetrate

Materiale: acciaio inox

Testa girevole svasata di fissaggio

Finitura	Codice
Inox satinato	1100 SS2 OSC

N.B.: a richiesta si può avere anche Inox lucido

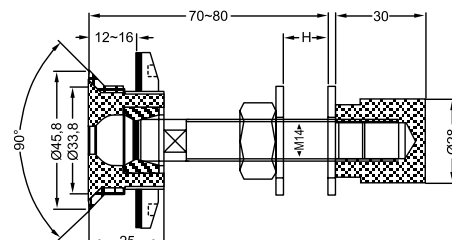

Testa girevole di fissaggio

Finitura	Codice
Inox satinato	1100 SS2 OFC

N.B.: a richiesta si può avere anche Inox lucido

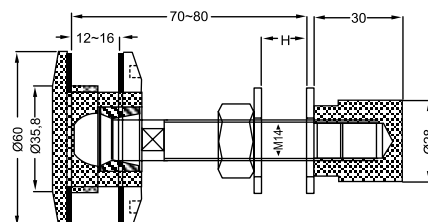

Montaggio centrale del braccio

Finitura	Codice
Inox satinato	1100 SS2 OCS

N.B.: a richiesta si può avere anche Inox lucido

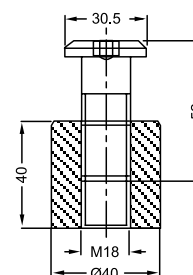

Montaggio per vetri

Montaggio per vetri su superfici tonde

Materiale: acciaio inox

Spessore vetro: da 8 - 10 e 12 mm

A) Modello squadrato

Misura	Sp. vetro	Finitura	Codice
45 x 45	8	Inox	1100 031 001
45 x 45	8	Inox lucido	1100 031 002
45 x 45	10	Inox	1100 031 003
45 x 45	10	Inox lucido	1100 031 004
55 x 55	8	Inox	1100 031 010
55 x 55	8	Inox lucido	1100 031 011
55 x 55	10	Inox	1100 031 012
55 x 55	10	Inox lucido	1100 031 013
55 x 55	12	Inox	1100 031 014
55 x 55	12	Inox lucido	1100 031 015

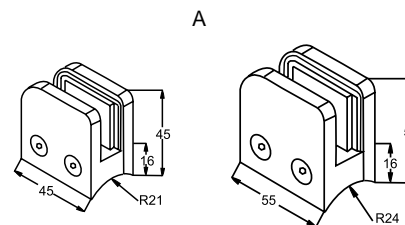

B) Modello stondato

Misura	Sp. vetro	Finitura	Codice
50 x 40	8	Inox	1100 031 021
50 x 40	8	Inox lucido	1100 031 022
62 x 45	8	Inox	1100 031 033
62 x 45	8	Inox lucido	1100 031 034
62 x 45	10	Inox	1100 031 035
62 x 45	10	Inox lucido	1100 031 036
62 x 45	12	Inox	1100 031 037
62 x 45	12	Inox lucido	1100 031 038

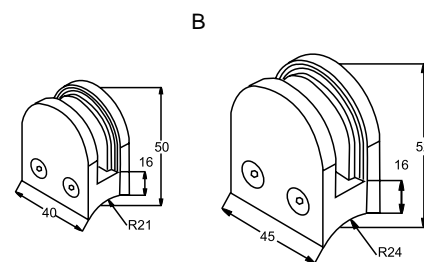

Montaggio per vetri su superfici piane

Materiale: acciaio inox

Spessore vetro: da 8 - 10 e 12 mm

C) Modello squadrato

Misura	Sp. vetro	Finitura	Codice
45 x 45	8	Inox	1100 031 041
45 x 45	8	Inox lucido	1100 031 042
45 x 45	10	Inox	1100 031 043
45 x 45	10	Inox lucido	1100 031 044
55 x 55	8	Inox	1100 031 051
55 x 55	8	Inox lucido	1100 031 052
55 x 55	10	Inox	1100 031 053
55 x 55	10	Inox lucido	1100 031 054
55 x 55	12	Inox	1100 031 055
55 x 55	12	Inox lucido	1100 031 056

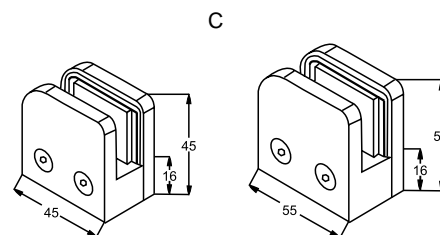

D) Modello stondato

Misura	Sp. vetro	Finitura	Codice
50 x 40	8	Inox	1100 031 061
50 x 40	8	Inox lucido	1100 031 062
50 x 40	10	Inox	1100 031 063
50 x 40	10	Inox lucido	1100 031 064
62 x 45	8	Inox	1100 031 071
62 x 45	8	Inox lucido	1100 031 072
62 x 45	10	Inox	1100 031 073
62 x 45	10	Inox lucido	1100 031 074
62 x 45	12	Inox	1100 031 075
62 x 45	12	Inox lucido	1100 031 076

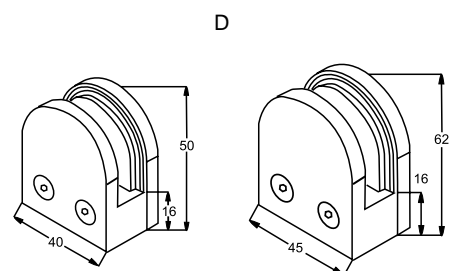

Montaggio per vetri a balcone



Montaggio per vetri su superfici piane

Materiale: lega d'alluminio
Spessore vetro: da 5 a 10 mm

Finitura	Codice
Cromata	1100 C31 00P

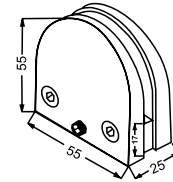

Montaggio per vetri su superfici tonde

Materiale: lega d'alluminio
Spessore vetro: da 5 a 10 mm

Finitura	Codice
Cromata	1100 C31 00T

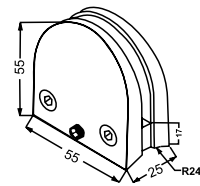

N.B.: a richiesta finiture oro e nera

3

Montaggio per vetri su superfici tonde e orizzontali

Materiale: ottone
Spessore vetro: 4 - 6/7 - 10 mm

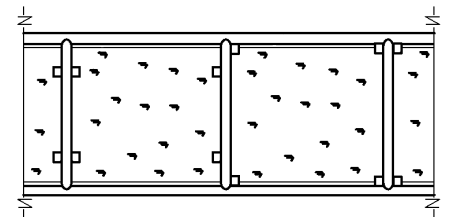

Tipo aperto

W	R	SP.	Finitura	Codice
12,7	25,4	10	Cromato	1100 PB3 91A
9,6	19	6/7	Cromato	1100 PB3 91B
6,35	12,7	4	Cromato	1100 PB3 91C

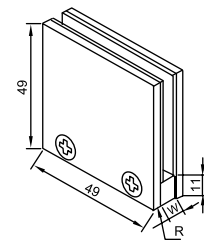

Tipo chiuso

W	R	SP.	Finitura	Codice
12,7	25,4	10	Cromato	1100 PB3 92A
9,6	19	6/7	Cromato	1100 PB3 92B
6,35	12,7	4	Cromato	1100 PB3 92C

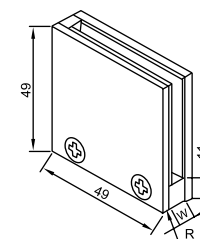

Montaggio per vetri a balcone

Montaggio per vetri su superfici tonde e inclinate

Materiale: ottone

Spessore vetro: 4 - 6/7 - 10 mm

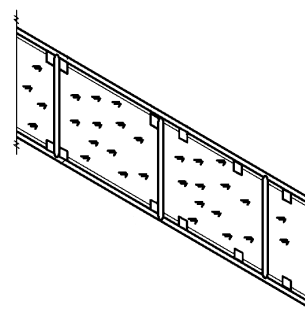

Tipo chiuso - angolo finale ottuso

W	R	SP.	Finitura	Codice
12,7	25,4	10	Cromato	1100 PB3 93A
9,6	19	6/7	Cromato	1100 PB3 93B
6,35	12,7	4	Cromato	1100 PB3 93C

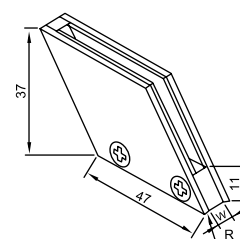

Tipo aperto

W	R	SP.	Finitura	Codice
12,7	25,4	10	Cromato	1100 PB3 94A
9,6	19	6/7	Cromato	1100 PB3 94B
6,35	12,7	4	Cromato	1100 PB3 94C

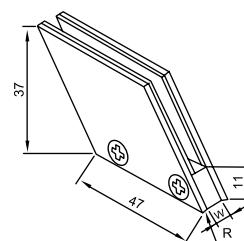

Tipo chiuso - angolo finale acuto

W	R	SP.	Finitura	Codice
12,7	25,4	10	Cromato	1100 PB3 95A
9,6	19	6/7	Cromato	1100 PB3 95B
6,35	12,7	4	Cromato	1100 PB3 95C

